

HOT AIR APPLICATIONS

haventic · hatronic · haflowtic

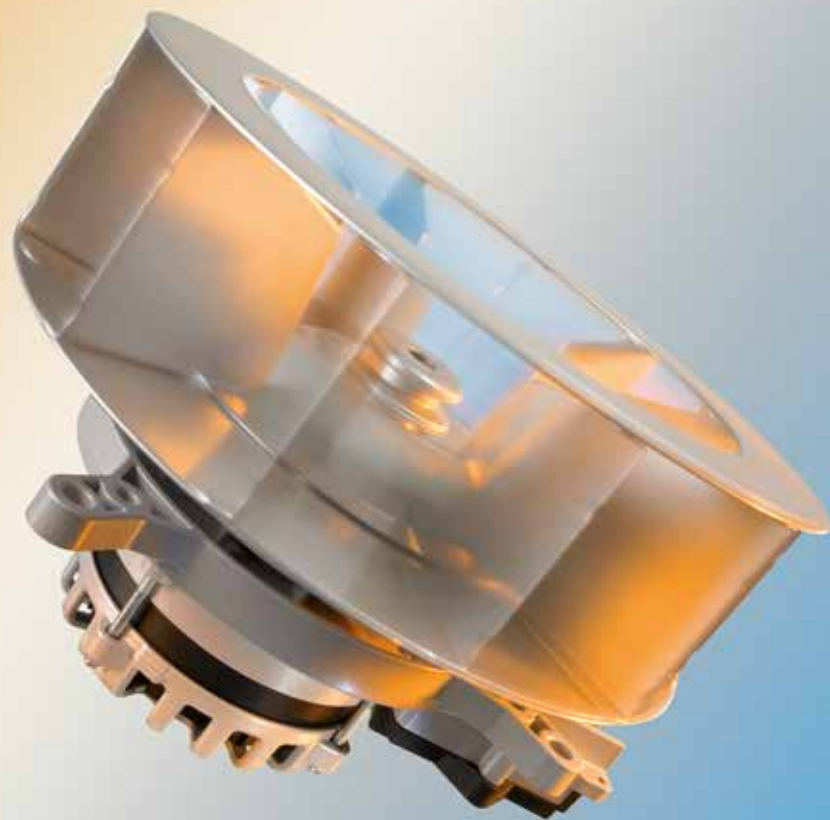

Your system partner for hot air applications

HANNING inside – this statement applies nowadays to thousands of hot air ovens worldwide. The reasons: We develop not only high-performance drive components, but also individual complete solutions that are matched to your technical requirements. That makes us the right system partner and innovation driver for all hot air applications. This is further substantiated by our **hatronic compact** frequency inverter (HAI) with pollution degree III.





moving ideas

Life is movement – something we have been infusing in the products of our customers for more than 70 years. Based on our slogan “moving ideas”, we at HANNING ELEKTRO-WERKE develop drive concepts and manufacture customized solutions that will put you ahead of the competition. As one of the leading manufacturers of electric and electronic drive systems and components in the world, that is our promise to you.

We as a system provider strive to think outside of the box and develop individualized industry-focused solutions, for instance for manufacturers of commercial ovens and combi-steamers. We know the market, understand your requirements and implement individual measures to achieve them. Be it fan drives, circulating and drain pumps or electronic controllers: At HANNING you get everything from a single source, optimally matched to another and designed for your hot air applications while ensuring longevity and resistance to high temperatures and chemicals.

moving ideas – typical HANNING. See for yourself!



haventic fan drives

At HANNING you will find the right hot air drive for your requirements.



Compact and energy efficient

The new **haventic varicon** EC fan motor with integrated frequency inverter sets new standards for the industry. It stands for innovative synchronous technology which features maximum efficiency in an extremely compact package.



2-in-1 – the rinsing system of the future

Self-cleaning ovens are technically complex and demand that the circulating and drain pumps interact seamlessly. Any company that needs to ensure that must combine both units into a single system – just like HANNING.



Be it synchronous or asynchronous technology, especially encapsulated, ready for installation with integrated rear oven panel or in different voltage versions for your overseas markets: We have the right solution for you or we will adapt it to your individual requirements.

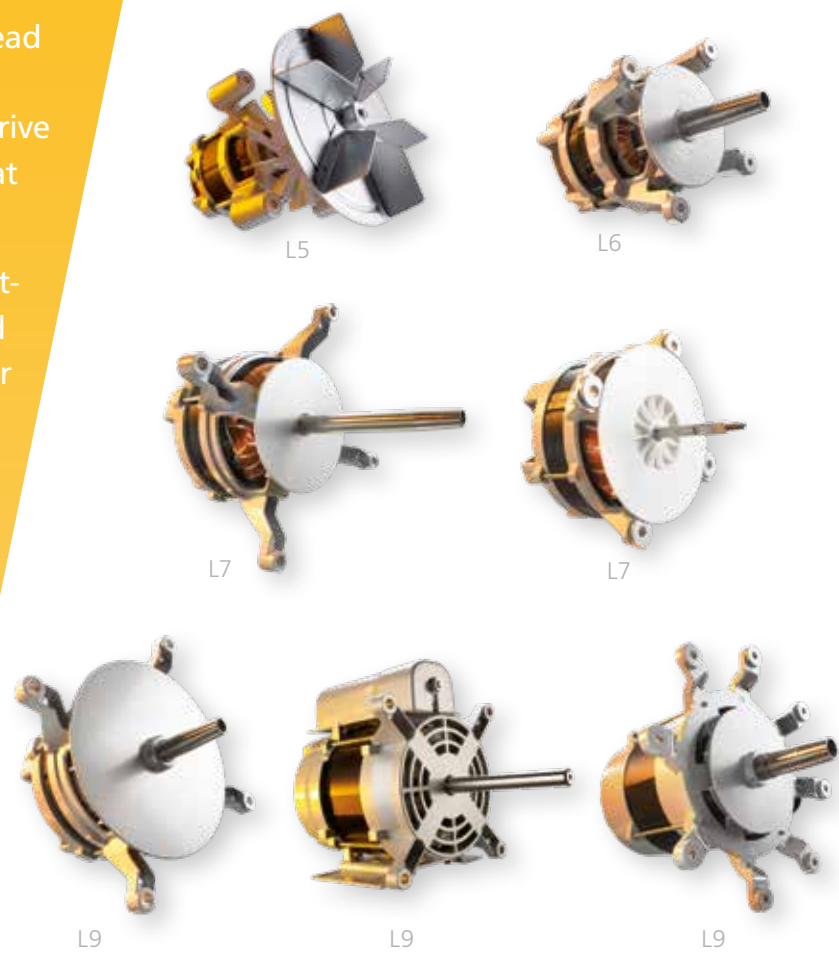

Various customized versions sizes L5 to L9.

The installation of many individual components takes time and valuable useful space. With our **haventic varicon** fan motor you save both. The electronics are after all integrated

in it, completely configured for your application and wired for installation. Nonetheless, the amount of technology built into it is not even noticeable from the outside.

Versatile thanks to the wide speed range of 400 to 7,000 rpm and a shaft output of 220 to 450 W

Optimally suited for ambient temperatures of up to 70°C and high air moisture

Minimum installation requirements due to integrated electronic module, wide variety of actuation options via bus systems (CAN or Modbus) and digital and analog I/O's

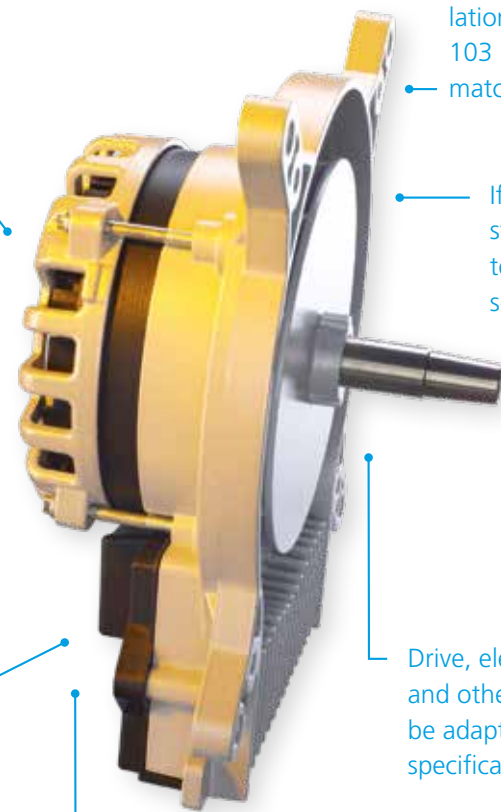

Extremely compact with installation depths between 83 and 103 mm. Design is variably matched to the device's shape

If necessary with integrated status request for motor temperature, speed, torque, sensors, etc.

Drive, electronic module and other components can be adapted to customer's specifications

Suited for worldwide use with our power supply unit at 50/60 Hz, from 100 – 240 V, permitting a drastic reduction of requiring different versions

What can be done to ensure that all pumps and sensors of a self-cleaning oven work together seamlessly? HANNING's answer: a solution that already combines all individual

components into one system during the development. We adapt the system exactly to your requirements.

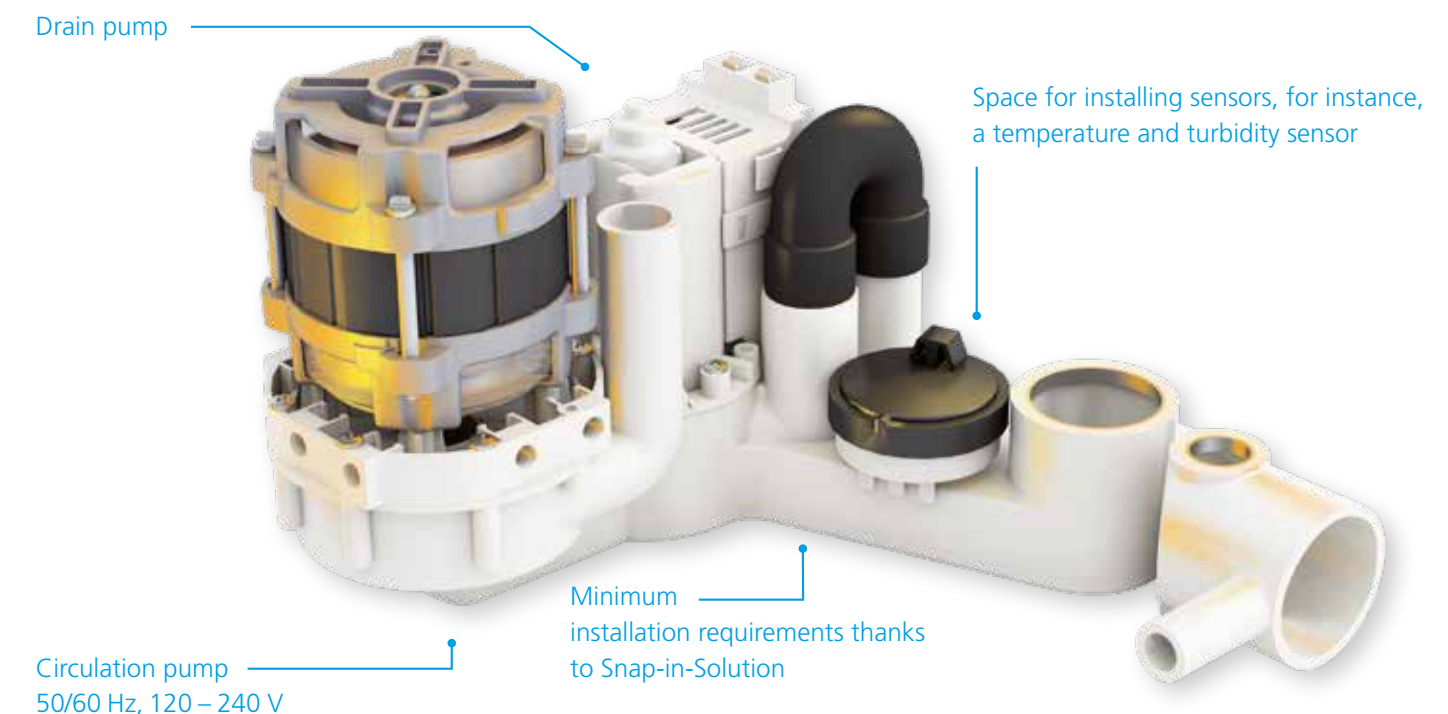

Further information can be found in our **haflowtic**, **hatronic** or **haventic** brochures.

“There is always room for improvement” – according to HANNING ELEKTRO-WERKE's slogan and with this in mind, we adapt our drives to your individual applications, carry out optimization measurements, take care of the requested approvals and much more. That makes us your first choice for developments for hot air applications.



HANNING

moving ■■■ ideas

HANNING ELEKTRO-WERKE GmbH & Co. KG
Holter Straße 90, D-33813 Oerlinghausen
Germany

Tel +49 (5202) 707-0 · Fax +49 (5202) 707-301
info@hanning-hew.com · www.hanning-hew.com

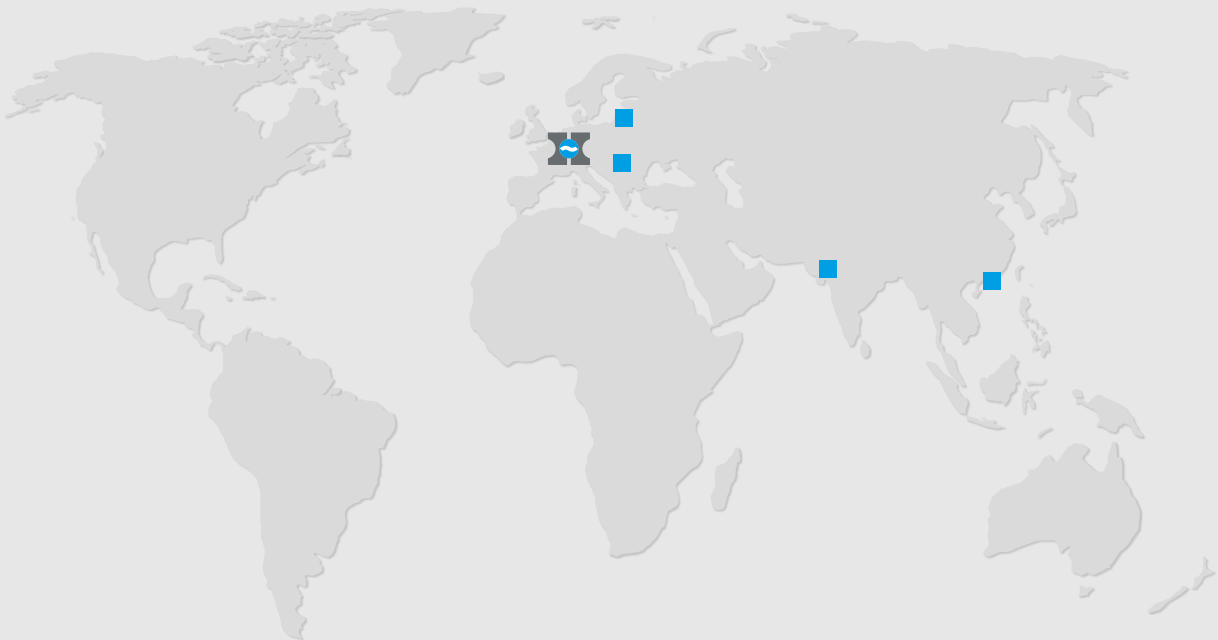

HANNING ELEKTRO-WERKE GmbH & Co. KG
Binning 5, D-17367 Eggesin, Germany

UAB HANNING VILNIUS
Vytenio 50, LT-03229 Vilnius, Lithuania
info@hanning-hv.com

HANNING MOTORS ROMANIA SRL
Strada Petre Carp Nr. 19, Judetul Bihor
410603 Oradea, Romania
info@hanning-hmr.com

HANNING (HONG KONG) Ltd.
Flat J, 20/F, Gold King Industrial Building
35-41 Tai Lin Pai Road, Kwai Chung, N.T., Hong Kong
info@hanning-hk.com

HANNING MOTORS INDIA Pvt. Ltd.
Plot No. 80-82 / 1+2, Alindra-Manjusar GIDC, Tal.: Savli
Dist.: Vadodara 391775, Gujarat, Indien
info@hanning-hmi.com